



---

# Cleveland County

NORTH CAROLINA

## INVITATION TO BID

Asphalt Paving EMS Base Station  
442 School House Road  
Casar, NC 28020

---

Cleveland County will receive bids for asphalt paving of the new EMS Base Station. The EMS Base Station is located at: 442 School House Road, Casar NC 28020

- The Civil Site Plan CSN101 is attached. An AutoCAD drawing is available for area measurements.
- The grading for the new building will start April 19th, 2021 and the new building set in place May 15th, 2021. Paving could start after modular new building set in place.
- The NCDOT – *Street and Driveway Access* permit application has been applied for. The Contractor shall notify the local NCDOT district engineer when the work begins and when it is completed
- The Contractor shall ‘stripe’ the four parking spots shown. White spray paint is acceptable
- The Contractor shall complete the site location 30 days after receipt of Notice to Proceed.
- The Contractor shall keep on file with the County a current Certificate of Liability Insurance and Proof of Workmen’s Compensation before work begins and keep in force throughout remainder of project.
- The Contractor will not be required to furnish a Performance or Payment Bond.
- The Contractor will be paid for the entire contract amount after completion of the project and after the County has inspected the sites and verified the contract completion.
- The Contractor shall visit and inspect the site prior to submitting a bid.
- **ALL BIDS ARE DUE ON OR BEFORE JULY 16, 2021—BY 3:00 PM.**
- Bids shall be submitted on the form provided in a sealed envelope.
- The sealed envelope shall be labeled with the project name and the bidder’s name.

## INVITATION TO BID

Asphalt Paving EMS Base Station  
442 School House Road  
Casar, NC 28020

---

Proposals can be submitted by any one of the following methods:

**Mail:**

Cleveland County Administrative Bldg.  
Finance & Purchasing Department  
Attn: Kim Lester  
PO Box 1210,  
Shelby, NC 28151

**Hand delivered:**

Cleveland County Administrative Bldg.  
2<sup>nd</sup> Floor  
Finance & Purchasing Department  
Attn: Kim Lester  
311 E. Marion St  
Shelby, NC

Or email proposals to: [Kim.Lester@clevelandcountync.gov](mailto:Kim.Lester@clevelandcountync.gov)

Administrative questions can be emailed to Kim Lester at:

[Kim.Lester@clevelandcountync.gov](mailto:Kim.Lester@clevelandcountync.gov)

If you have any project scope questions, please contact:

Greg Pering  
County Engineer  
American Red Cross Building  
1333 Fallston Road, Shelby, NC 28150  
D: (980) 484-4620  
C: (704) 419-9014  
E: [Greg.Pering@clevelandcountync.gov](mailto:Greg.Pering@clevelandcountync.gov)

# BID FORM

INVITATION TO BID  
Asphalt Paving EMS Base Station  
442 School House Road  
Casar, NC 28020

To: Cleveland County Finance & Purchasing Department  
PO Box 1210  
ATTN: Kim Lester  
311 E. Marion Street  
Shelby, NC 28151

From: \_\_\_\_\_  
\_\_\_\_\_  
\_\_\_\_\_  
\_\_\_\_\_

Date: \_\_\_\_\_

As the undersigned contractor, I have inspected the above referenced property and understand the extent and character of the work to be completed as described in the *Invitation to Bid*.

I propose to furnish all labor and equipment necessary to accomplish all work as described in the *Invitation to Bid*.

- Total Project Costs: \$ \_\_\_\_\_

I agree to the attached Terms & Conditions and will complete all work within 30 days of receipt of the *Notice to Proceed*.

\_\_\_\_\_  
Signature

\_\_\_\_\_  
Company Address Line 1

\_\_\_\_\_  
Print Name

\_\_\_\_\_  
Company Address Line 2

\_\_\_\_\_  
Contractor's License Number

\_\_\_\_\_  
Work Phone

\_\_\_\_\_  
Expiration Date

\_\_\_\_\_  
Cell Phone

\_\_\_\_\_  
Company Name

\_\_\_\_\_  
Email

---

## SERVICE CONTRACT AND INDEMNITY AGREEMENT

County of Cleveland, North Carolina (hereinafter "County") agrees to secure the services of the company or individual (hereinafter "Contractor") indicated in the signature section below to provide labor for a particular job or services of a limited special nature. The Contractor has been offered contract work by the County and the work will be performed at site(s) owned or operated by the County. Prior to signing contract and prior to commencing services, County and Contractor have provided a jointly completed "Worker Status Determination Report" and "Vendor Registration Form" for inspection by qualified staff in the County Finance & Purchasing Department. In consideration of the foregoing premises, the mutual promises contained herein and other good and valuable consideration, the receipt and sufficiency of which are hereby acknowledged, the parties hereto agree as follows:

### TERMS AND CONDITIONS

- 1. Services:** The services to be performed by the Contractor shall be as described in documents attached hereto and incorporated herein by this reference. The work shall include all labor and materials which will be paid by the Contractor and necessary for completion of the work. Label attached documents sequentially beginning with Attachment 1. If more than two documents are attached, provide as Attachment 1 a list that identifies all documents attached and remaining documents shall be sequentially numbered.
- 2. Payment:** The Contractor will be paid as outlined in attached documents.
- 3. Warranty:** The Contractor shall and hereby does warranty all workmanship and materials for up to at least one year after completion of the project. Any materials, equipment, or workmanship discovered to be inferior or which fails to perform as reasonably expected shall be repaired or replaced by the Contractor, at the Contractor's expense, within a reasonable time period of the Contractor being notified of such discovery.
- 4. Independent Contractor:** The Contractor agrees that he/she is an "independent contractor" not under the control or supervision of the County and, therefore, not eligible for County employee benefits (such as health insurance and workers' compensation insurance). The County's health insurance policy and workers' compensation insurance will not cover the Contractor in the event of sickness, illness, injury, or accident. The personnel policies of the County do not apply to the Contractor. The Contractor does not make this agreement under any duress.
- 5. Taxes/Withholdings:** The Contractor is responsible for all federal and state employment taxes or other required withholdings. The County will not pay on the Contractor's behalf any federal or state income tax, social security tax, or any other withholding tax or benefit.
- 6. IRS Form 1099:** The Contractor will not be required to fill out an application for employment. The Contractor will not be provided a W-2 form, but the Contractor's pay will be reported to the IRS. The County will provide an IRS Form 1099 at the end of the calendar year to each Contractor per IRS rules and regulations.
- 7. Limited Need for Services:** As an "independent contractor", the Contractor's services may be needed for a limited time and the need may end at any time for any reason.
- 8. Compliance with Applicable Laws:** The parties to this Contract agree that the laws of the State of North Carolina shall govern the validity, construction, interpretation, and effect of this contract. The Contractor shall perform the work as provided for by the contract in compliance with all applicable federal, state and local regulations and laws including, but not limited to, the OSHA standards set and enforced by the Department of Labor, minimum hour and wage regulations, equal opportunity employment laws, confidentiality, state incorporation laws, state rules concerning the collection and reporting of sales and use taxes, restriction against officers and employees of the County deriving personal benefit(s) from the Contractor, disclosure of lobbying activities, etc. This Contract and the work to be done as described herein is also subject to the provisions of all pertinent local government ordinances which are hereby made a part hereof with the same force and effect as if specifically set out herein.

9. **Insurance and Bonding:** Prior to commencing services and throughout the term of this agreement, the Contractor and all subcontractors shall maintain in force adequate applicable insurance coverage for property and general liability, malpractice, workers compensation, and vehicle liability. When the minimum required insurance is determined to be insufficient, the Contractor will maintain in force insurance reasonably appropriate to the work to be undertaken by the Contractor. When exempt from workers compensation or other insurance coverage, the Contractor shall provide documented proof of exemption. Further, the Contractor agrees to provide a Certificate of Liability to the County for all applicable insurance coverage.

10. **Indemnity:** To the fullest extent permitted by law, the Contractor agrees to and hereby does indemnify, defend, and hold harmless the County and County's officers, agents, and employees from and against any and all losses, costs, damages, obligations, and expenses incurred by the County (including, without limitation, attorney's fees) that arise in connection in any way, directly or indirectly, associated with the work to be performed by the Contractor or any of its agents, subcontractors, and employees (including, without limitation, any claim for personal injury, death, sickness, or disease, or payment arising from an employee of Contractor, any sub-Contractor or any other party), whether in any event such claim arises prior to completion of and payment for the contracted work or thereafter.

11. **Damage to County Property:** The Vendor shall be responsible for any damage to or loss of the County's equipment or facilities arising out of an act or omission of the Vendor or its authorized user and deemed reasonable by either (1) both County and Contractor, (2) mediator, or (3) court/judge.

12. **Additional Terms:** The Contractor hereby also formally agrees to the entire set of general terms and conditions at <http://www.ccncgov.com/FinanceD/vendors.html>, which aids the County in its efforts to comply with federal rules and regulations.

13. **Amendment of the Contract:** No modification or amendment of the terms hereof shall be effective unless written and signed by the authorized representatives of all parties entitled to receive a right or obligated to perform a duty under this Contract. On behalf of the County, both the Authorized County Department Representative and the County Finance Director must sign and a board chairperson may also be required to sign. A signed original is to be fastened to the original Contract with signed copies retained by all parties.

14. **Complete Agreement:** This Contract and all attachments constitute the complete agreement and understanding between the parties. All prior and coexisting agreements and understandings, whether oral or written, are to be without effect in the construction of any provision or term of this contract if they alter, vary, or contradict this Contract.

## SIGNATURE SECTION

1. **Subject to Contractor Approval:** On behalf of the Contractor, please indicate consent to these terms and conditions by signing and completing the lines below.

---

Printed Name of Company or Individual

---

Authorized Representative: Signature / Printed Name / Date

2. **Subject to Board Approval:** On behalf of the Cleveland County Board of Commissioners, the Order to demolish this dwelling was approved on: \_\_\_\_\_

---

Clerk to the Board of Commissioners: Signature / Seal

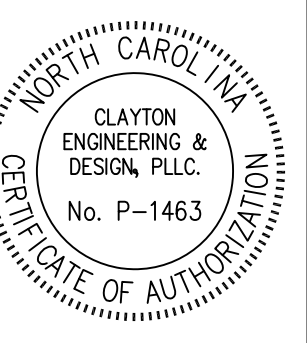

**CLAYTON**  
ENGINEERING & DESIGN

NOT FOR CONSTRUCTION

222 N. LAFAYETTE ST., SUITE 100  
SHELBY, NORTH CAROLINA 28150  
904.1511 ST. SOUTHEAST  
FLOOR 400 SHELBY, NORTH CAROLINA 28602  
PROJECT # 2021-001  
www.hollandhamrick.com

**HOLLAND  
HAMRICK**  
ARCHITECTS, P. A.

PROJECT TITLE  
EMS BASE STATION  
for  
CLEVELAND COUNTY  
Casar, North Carolina

COMM. #: 2415  
DATE: 1-6-2021  
CONSTRUCTION DOCUMENTS

REVISIONS:

SHEET TITLE  
CIVIL  
SITE PLAN

CSN101

**PROJECT DETAILS**

- OWNER  
-CLEVELAND COUNTY BOARD OF EDUCATION  
-400 W. MARION ST.  
-SHELBY, NC 28150
- PARCEL I.D. NO. = 2624093853
- SITE ZONING = MUNICIPAL ZONING
- TOTAL SITE ACREAGE = 18.462 ACRES.
- TOTAL DISTURBED ACREAGE = ACRES
- BUILDING SIZE: SQ FT
- PARKING REQUIRED: SPACES  
PROVIDED: SPACES
- WATERSHED DISTRICT: WS-IV
- IMPERVIOUS AREA  
BUILDING: SQFT  
PARKING: SQFT  
TOTAL: SQFT  
BUILT UPON: %
- SUBJECT PROPERTY IS IN DESIGNATED FLOOD ZONE "X" (AREAS DETERMINED TO BE OUTSIDE THE 0.2% ANNUAL CHANCE FLOODPLAIN) FIRM PANEL #5710262400J

NOTES THIS SHEET:

- THE OWNER SHALL SCHEDULE A PRE-CONSTRUCTION CONFERENCE WITH THE CLEVELAND COUNTY ENGINEERING DIVISION BEFORE ANY WORK BEGINS. THE OWNER SHALL NOTIFY THE CLEVELAND COUNTY ENGINEERING DIVISION AT LEAST 7 CALENDAR DAYS PRIOR TO COMMENCING ANY WORK ON THE SITE. FAILURE TO PROVIDE REQUIRED NOTICE SHALL RESULT IN THE OWNERS RESPONSIBILITY TO UNCOVER ANY PRIOR BELOW-GRADE WORK FOR VISUAL INSPECTION BY THE ENGINEERING DIVISION.
- COORDINATE ALL CURB AND STREET GRADES IN INTERSECTION WITH INSPECTOR.
- ALL ROAD IMPROVEMENTS ARE TO BE COORDINATED WITH CLEVELAND COUNTY AND NCDOT ENGINEERING DEPARTMENT PRIOR TO CONSTRUCTION.
- IN ROLLING AND HILLY TERRAINS, SWEEPING OF THE STONE BASE AND/OR APPLICATION OF A TACK COAT MAY BE REQUIRED NEAR INTERSECTIONS. THESE REQUIREMENTS SHALL BE ESTABLISHED BY THE INSPECTOR BASED ON FIELD CONDITIONS.
- APPROVAL OF THIS PLAN IS NOT AN AUTHORIZATION TO GRADE ADJACENT PROPERTIES. WHEN FIELD CONDITIONS WARRANT OFF-SITE GRADING, PERMISSION MUST BE OBTAINED IN WRITING FROM PROPERTY OWNERS.
- IN ORDER TO ENSURE PROPER DRAINAGE, KEEP A MINIMUM OF 0.5% SLOPE ON THE CURB.
- POLE BASES AND ELECTRICAL DESIGN FOR PARKING LOT LIGHT POLES SHALL BE SUBMITTED PRIOR TO BEGINNING INSTALLATION.
- UNSUITABLE SUBBASE MATERIAL NOT IDENTIFIED BY THE SOIL TESTS, BUT LOCATED DURING CONSTRUCTION, MUST BE REMOVED FROM THE RIGHT-OF-WAY AND REPLACED WITH BACKFILL.
- WHERE VERTICAL CURB AND GUTTER EXIST, ALL DRIVEWAY RAMPS SHALL BE CONSTRUCTED OF PORTLAND CEMENT A MINIMUM OF 6-INCHES DEEP. THE RAMP MUST RISE 4-INCHES ABOVE THE FLOW LINE OF THE GUTTER AT A POINT NO CLOSER THAN 2- FEET FROM THE GUTTER.
- ALL WORK TO BE COMPLETED IN NCDOT R/W TO BE COORDINATED WITH NCDOT.

STANDARD DUTY ASPHALT

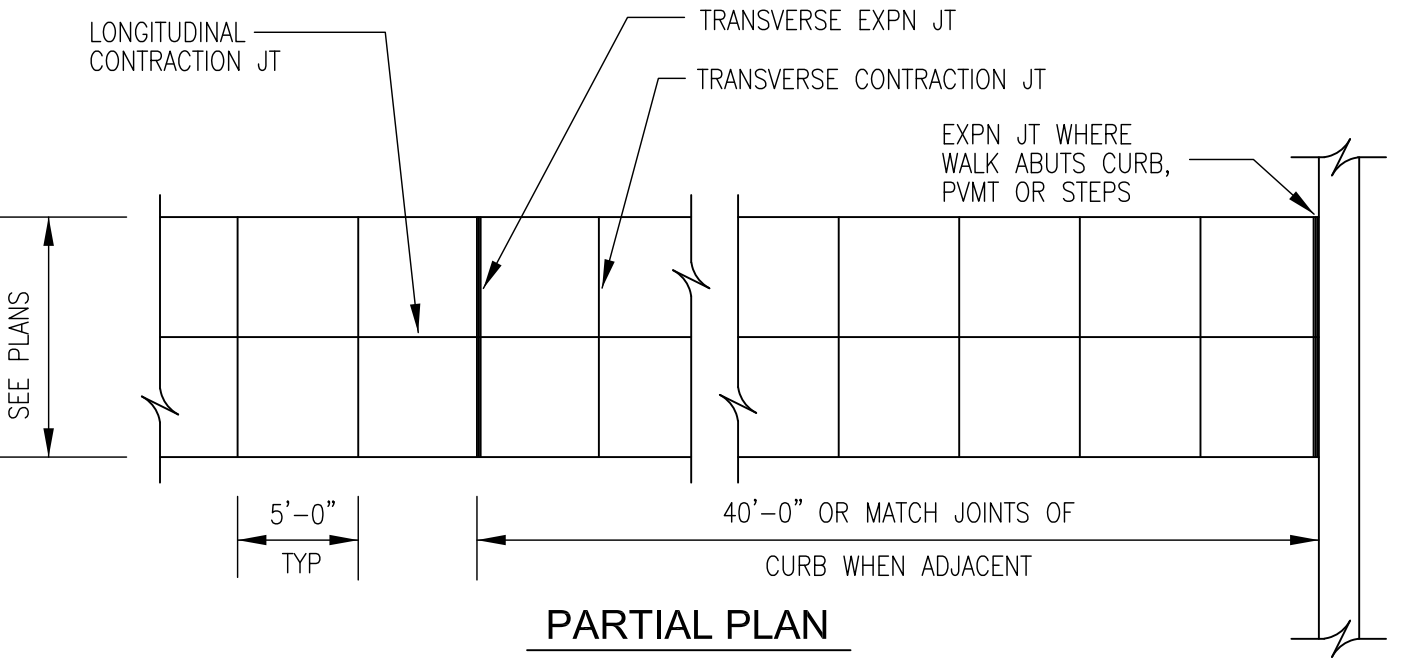
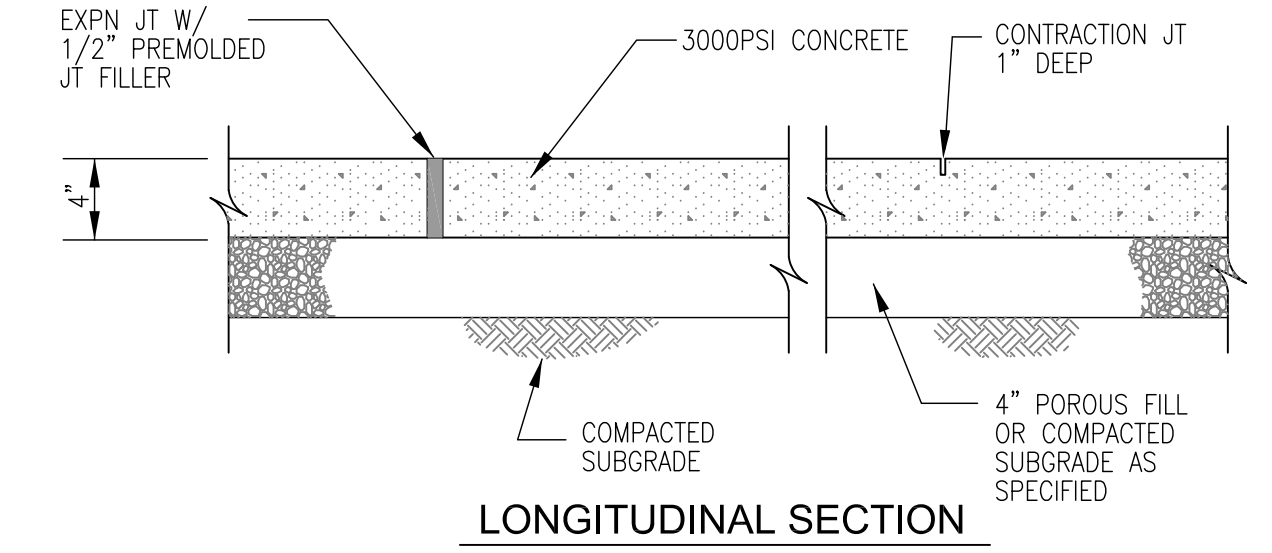
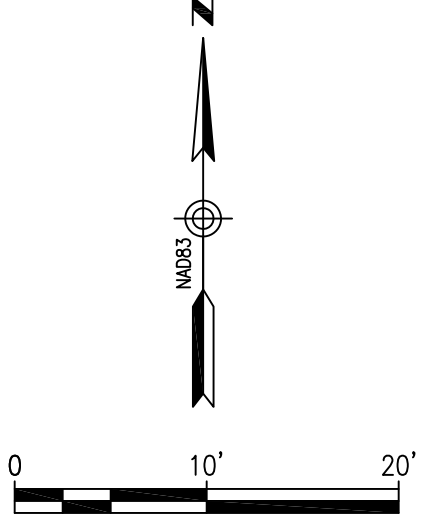

WALK WIDTH	LONGITUDINAL CONTRACTION JOINT
- 5'-11"	NONE
6'-0" - 7'-11"	ONE ALONG WALK AT CENTERLINE
8'-0" - 12'-0"	TWO ALONG WALK AT THIRD POINTS

**STANDARD SIDEWALK DETAILS**  
NO SCALE

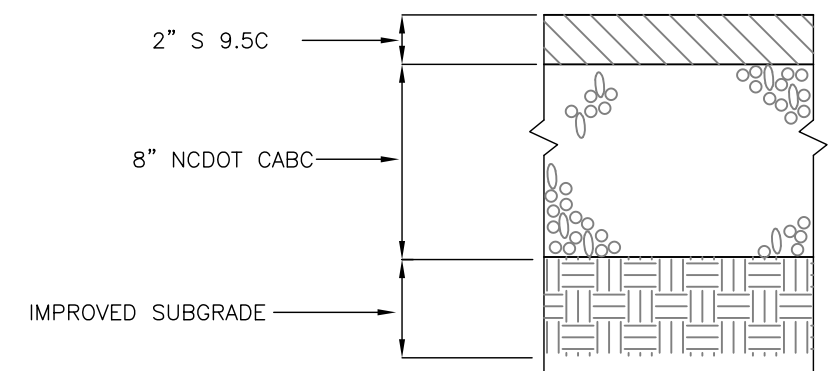

**STANDARD DUTY PAVING SECTION**  
NO SCALE

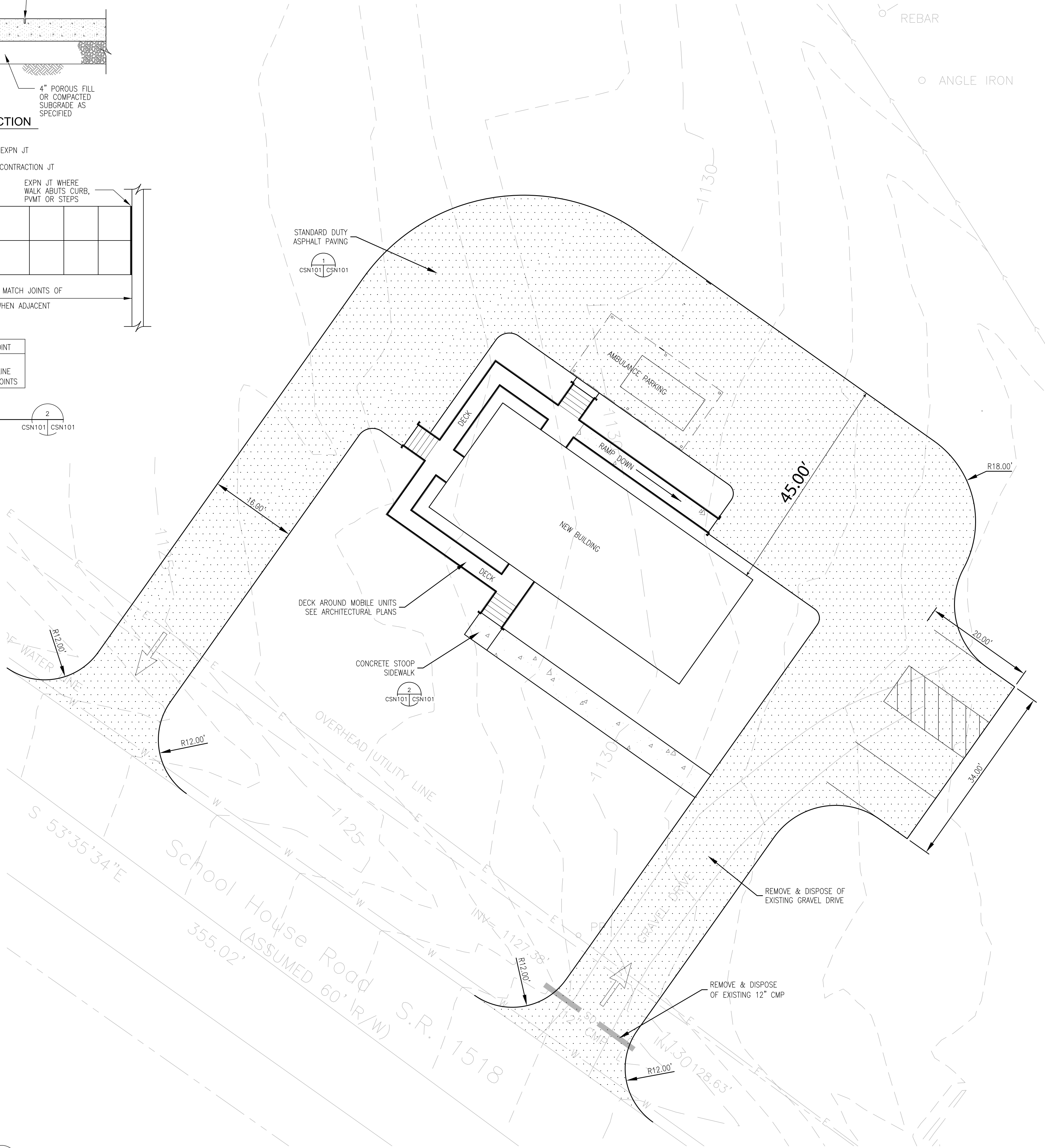

**SITE PLAN**  
SCALE: 1"=10'